

Slim Line Industrial Ethernet Unmanaged Switches

Low Cost and Ultra-Reliability in the Same Package!

SIXNET Slim Line Industrial Ethernet Switches provide advanced performance that enables you to achieve real-time deterministic operation. These ruggedized switches are industrial hardened to provide superior reliability. They require no user setup and immediately start operating as soon as you power them up. SIXNET switches are designed to make your job easier.

Product Highlights

- Slim packaging fits on your DIN rail
- High performance and value
- Truly industrial hardened design
- Dual power inputs keeps you running
- Plug & play saves you time and money

Real-time operation

- Intelligent routing - No collisions!
- Ideal for any system

SIXNET reliability and long-term support

- Ultra-reliable 1,000,000+ hours MTBF

Plug and play simplicity

- Auto-sensing for speed and duplex
- Auto-mdi/mdix-crossover and auto-polarity

Industrial tough – ready for any application

- Dual power inputs with spike protection
- DIN rail or direct panel mounting

5, 8 and 9 Port Models are Available
with an Optional Fiber Optic Port



Replace those office-grade or other so-called industrial grade switches with these truly rugged switches from SIXNET.

SIXNET knows industrial –

We have been designing industrial hardware such as Remote Terminal Units for over 20 years and have used this expertise to design the toughest Ethernet switches on the market. Don't trust your critical communications to so-called industrial hardware from commercial switch manufacturers. SIXNET switches give you proven assurance that your system will keep running for years to come.

Certified to Perform:



ISO9001
Certified



European
Community



UL508
for Safety



USA/Canada
Emissions



Lead & Hazardous
Substance Free

SIXNET Switches are Real-time, Rugged and Reliable

SIXNET Industrial Ethernet Switches

Ensure that your critical automation and control communications stays running. These ruggedized switches connect to any Ethernet device and provide the important features you need:

- Simplify Installation
- Increase Reliability
- Improve Network Bandwidth
- Ensure Real-time Operation
- Supports Deterministic Control

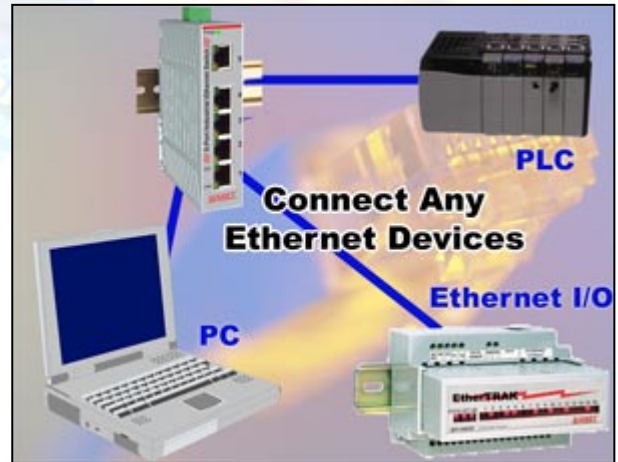

Why a SIXNET Industrial Ethernet Switch?

SIXNET Real-time Switches are truly industrial. SIXNET has over 20 years experience designing Remote Terminal Units for the toughest applications and has applied this expertise to design the most rugged and reliable Ethernet switches. Their tough packaging and protected circuitry keep them working under conditions that may cause other so-called industrial switches to quickly fail. Industrial applications are demanding - it gets hot, it gets cold - the power browns out or spikes wildly - and you need a reliable industrial switch that can keep on going.

Real-time deterministic performance

SIXNET Real-time Switches are one of the best and easiest ways to ensure the real-time operation of your automation and control system. They provide high throughput (3.2 Gbps, non-blocking) to ensure no delays and special handling for the many repeated short messages found in real-time polled systems. With plug and play ease, simply install these active switches and you'll immediately reap the benefits of increased performance. By providing enhanced message routing and eliminating message collision, these switches allow for true network determinism.

SIXNET Switches deliver ultra-reliability

SIXNET Real-time Switches have field-proven reliability of more than 1,000,000 hours MTBF. These SIXNET industrially hardened switches are rated to survive in your harsh environment – even outdoors in marine and military applications. You can count on SIXNET, who has been making industrial hardware for over 20 years!

Industrial switches survive heat & cold

SIXNET industrial switches work reliably through the dead of winter and those hot summer days. Unlike some industrial switches that are only screened commercial switches (this means they are not truly designed for extended temperature operation), SIXNET industrial switches are designed for those places that you don't want to be - over a wide operating temperature range. Over one billion running hours without a temperature related failure prove that SIXNET industrial switches survive!

Lose those bulky power transformers

SIXNET Real-time switches run directly on the DC power that you already have in your control cabinet. Get rid of those cumbersome AC outlet transformers. No AC power means fewer safety issues. If you ship your equipment internationally, you can forget about the headaches caused by different line voltages and incompatible power plugs.

Forget the Velcro and makeshift brackets

SIXNET industrial switches can be DIN rail or direct panel mounted - right out of the box. Their compact footprint fits easily into equipment-filled enclosures. No extra mounting accessories are need!

SIXNET Industrial Switches Make Your Job Easier

Just snap these switches onto the rail, plug in your network cables, and sit back and watch the data flow, year after year. These switches have been specifically designed to make your job easier.

SIXNET®

331 Ushers Road, P.O. Box 767 • Clifton Park, NY 12065 USA • +1 (518) 877-5173
Fax +1 (518) 877-8346 • <mailto:sales@sixnetswitch.com> • <http://www.sixnetswitch.com>

Performance Specifications	
General	5, 8 or 9 Ethernet ports
Ethernet switch type	Intelligent store & forward
Ethernet protocols supported	All IEEE 802.3
RJ45 ports (shielded)	10/100BaseTX
RJ45 speed (10 or 100 Mbps)	Auto-negotiation
RJ45 MDI/MDIX and TD/RD	Auto-crossover and auto-polarity
Fiber optic port speed	100BaseFX (100 Mbps)
Fiber optic port wavelength	1300 nm center
Fiber multimode (mm) typical	50 or 62.5/125 um (SC or ST)
Fiber singlemode (sm) typical	9 or 10/125 um (SC or ST)
Fiber max. distance (full duplex) (see web for details)	4 km (mm), 20 (sm) or 40 km (long haul) or more (contact SIXNET)
Typ. latency for 100 Mbps ports	5 us + frame time Varies on load
Fiber duplex operation	Full duplex
MAC addresses supported	1024
Memory bandwidth	3.2 Gbps
Environmental	DIN rail or direct panel mounting
Power input	Redundant input terminals
Input power (typical - all ports active at 100 Mbps) (Max. 6 W)	2.0 W (5-port without fiber) 3.0 W (5-port with 1 fiber) 4.0 W (8-port without fiber) 5.0 W (9-port with 1 fiber)
Power Input	10-30 VDC
Transient protection	15,000 watts peak
Spike Protection	5,000 watts (10 times for 10 us)
Ethernet isolation	1500 VRMS 1 minute
Operating temperature range	-10 to +60 °C
Storage temperature range	-40 to +85 °C
Humidity (non-condensing)	5 to 95% RH
Vibration	IEC68-2-6
Electrical safety	 UL508/CSA C22, EN61010-1
EMI emissions	
EMC immunity	
Eye safety (fiber models)	IEC60825-1, Class 1; FDA 21 CFR 1040.10 and 1040.11
Packaging material and protection	ABS with IP30 protection
Dimensions (L x W x H)	See next page

Specifications are subject to change. Consult factory for latest information.

Ordering Guide	
SL-5ES-1	5 RJ45 10/100 ports
SL-5ES-2SC SL-5ES-2ST	4 RJ45 ports & 1 multimode fiber optic port with SC or ST style connector
SL-5ES-3SC SL-5ES-3ST	4 RJ45 ports & 1 singlemode fiber optic port with SC or ST style connector
SL-8ES-1	8 RJ45 10/100 ports
SL-9ES-2SC SL-9ES-2ST	8 RJ45 ports & 1 multimode fiber optic port with SC or ST style connector
SL-9ES-3SC SL-9ES-3ST	8 RJ45 ports & 1 singlemode fiber optic port with SC or ST style connector
Accessories:	
RM-PS-024-01F	Power supply – AC to 24VDC, 1A, with integrated power bus
ET-PS-024-02	Power supply – AC to 24VDC, 2A, with compact packaging
SP-ETH-2	Dual port surge & lightning protector

Hardware Highlights:

- 5, 8 or 9 port truly industrial Ethernet switch with an optional fiber optic port (multimode or singlemode)
- Redundant power inputs and surge protection
- UL/CSA and CE rated for industrial applications
- DIN rail or direct panel mounting (no extra kits required)

Networking Features:

- Store and forward wire speed switching – no delays
- Support for up to 1024 MAC addresses
- Automatic address learning, aging and migration
- Full-Duplex operation with flow control (no collisions!)
- Auto crossover (MDI/MDIX) and auto polarity

Ethernet Compliance:

- IEEE 802.3 (10Mbps Ethernet supports legacy devices)
- IEEE 802.3u (Fast Ethernet 100Mbps for newer devices)
- IEEE 802.3x (Full-Duplex with Flow Control)

Typical Switch Application:

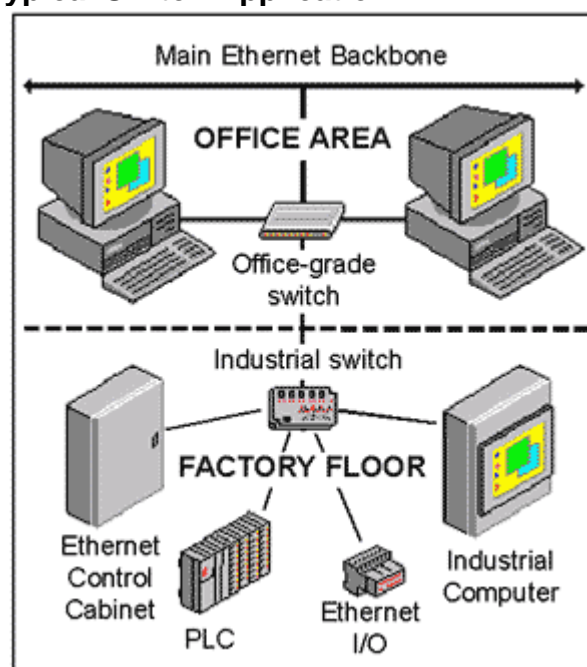

An industrial Ethernet media converter is also available. The SL-2ES converts your 10/100 RJ45 copper to fiber optic for links up to 120 km.



SIXNET®

331 Ushers Road, P.O. Box 767 • Clifton Park, NY 12065 USA • +1 (518) 877-5173
 Fax +1 (518) 877-8346 • <mailto:sales@sixnetswitch.com> • <http://www.sixnetswitch.com>

Mechanical Dimensions

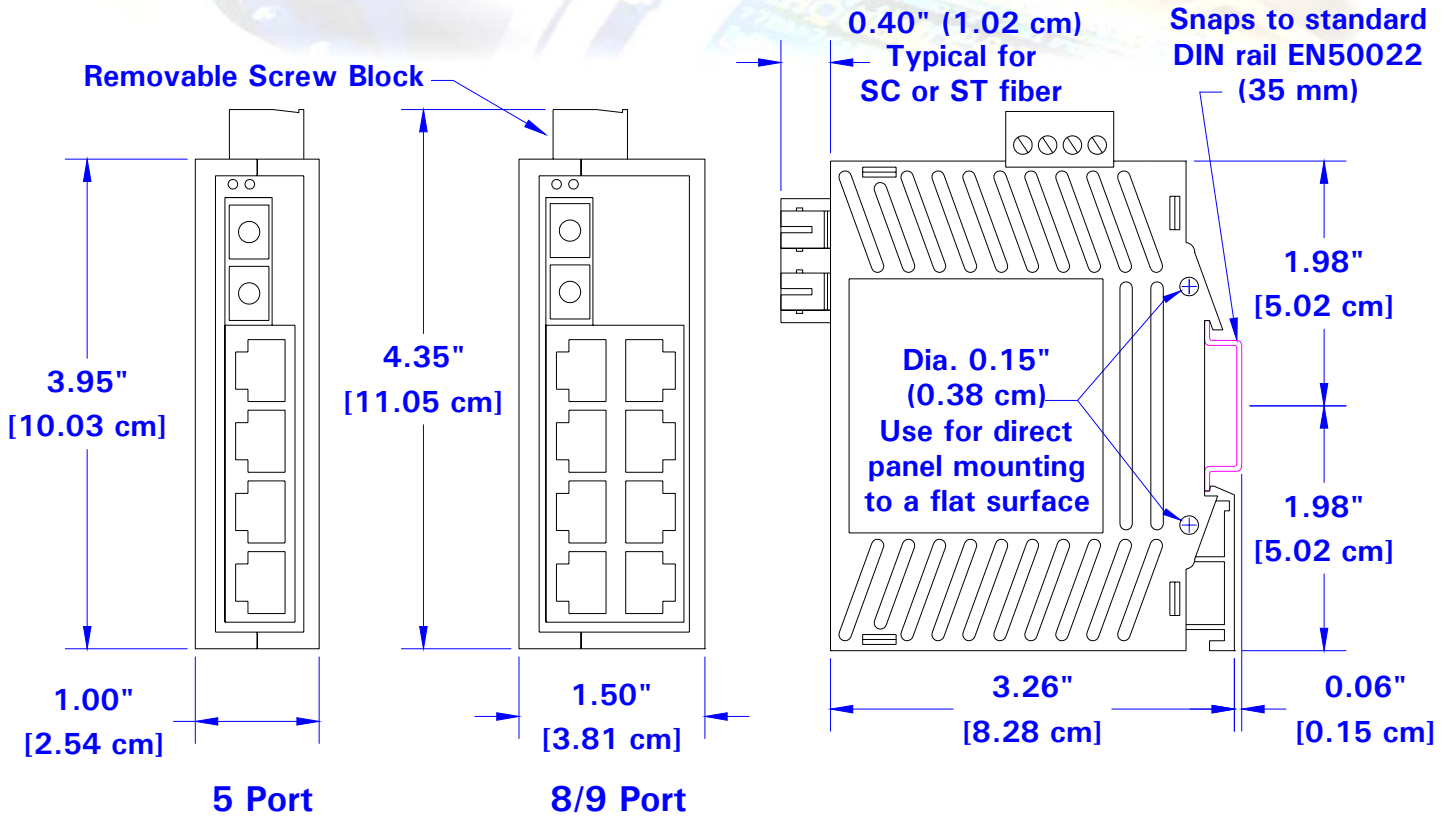

Power Connections

Single DC Power

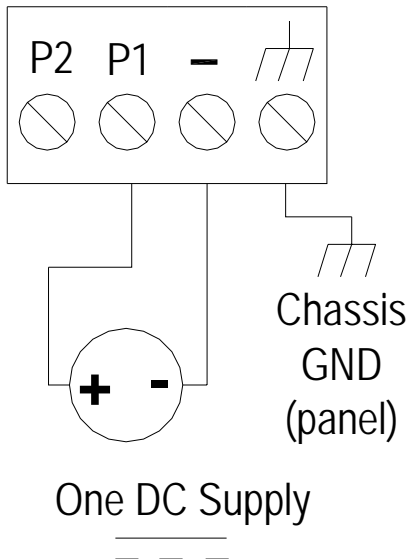

Redundant DC Power

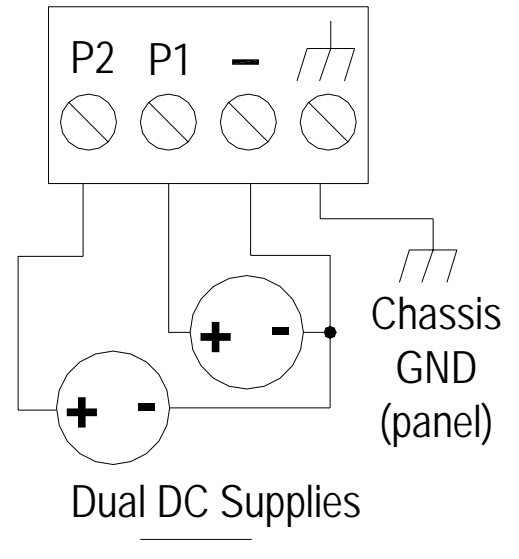

SIXNET®

331 Ushers Road, P.O. Box 767 • Clifton Park, NY 12065 USA • +1 (518) 877-5173
 Fax +1 (518) 877-8346 • <mailto:sales@sixnetswitch.com> • <http://www.sixnetswitch.com>

A Complete Family of Automation & Connectivity Solutions

Ethernet and RS485 I/O

SIXNET can provide you the building blocks for the open systems you are looking for. Three complementary families of modular DIN rail mounted I/O provide local, remote, enterprise level, or Internet I/O solutions.



Industrial Telephone Modems

SIXNET rugged industrial modems eliminate the hassles of mounting a telephone modem in an industrial enclosure. These robust modems are rated for -30 to +70 °C industrial operation.

Industrial Ring and Managed Switches

SIXNET also offers industrial Ethernet Switches that support fault-tolerant rings, Rapid Spanning Tree Protocol for redundancy, SNMP for easy network management and much more. These switches are rugged, reliable, real-time and most of all, secure.

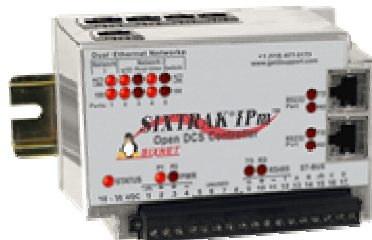
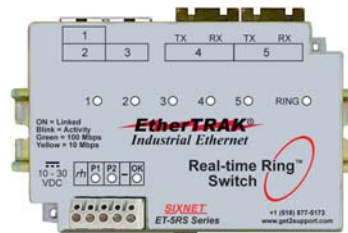

Controllers & RTUs with Open-Source Linux

SIXNET IPm is a combination of installation-ready industrial controllers & RTUs and a wealth of powerful software solutions. IPm offers the reliability of a PLC, the familiarity of powerful Windows programming and configuration utilities, all combined with powerful open-source Linux flexibility.



Request Your
FREE Product CD at
<http://www.sixnetswitch.com>

Contact your SIXNET Applications Engineer Today!

For the latest information, check out
<http://www.sixnetswitch.com>

Slim Unmanaged Switch Datasheet - Rev 4-Jan-07

SIXNET®

331 Ushers Road, P.O. Box 767 • Clifton Park, NY 12065 USA • +1 (518) 877-5173
Fax +1 (518) 877-8346 • <mailto:sales@sixnetswitch.com> • <http://www.sixnetswitch.com>