



IQ FLOW

Micro fluidic Mass Flow and Pressure Meters/Controllers
with high intrinsic quality

> Introduction

Bronkhorst High-Tech B.V., the European market leader in thermal Mass Flow Meters/Controllers and Electronic Pressure Controllers, has over 25 years of experience in designing and manufacturing precise and reliable measurement and control devices. With a wide range of instruments, Bronkhorst High-Tech is offering innovative solutions for many different applications in many different markets. The instruments are made to customers' specification, in various styles, suitable for use in laboratory, industrial environment, hazardous areas, semiconductor or analytical installations.

> Micro fluidic flow / pressure controllers

Equipment manufacturers are looking for compact solutions to monitor or control the gas flow or pressure in their system. Previously, conventional Mass Flow and Pressure Meters and Controllers have needed a footprint of 1.5", as for instance specified in the NeSSI™ system. Now, and in close co-operation with TNO-TPD (leading Dutch institute for applied physics) Bronkhorst High-Tech has developed the IQ FLOW mass flow sensor. Due to the use of micro solid state technology (MEMS), Bronkhorst has been able to halve the footprint dimension to 0.75", thereby realising the ultra compact flow and pressure controllers.

> Customer specific design

A core philosophy of Bronkhorst High-Tech is to form close working links and collaborations with original equipment manufacturers to ensure optimised integration of our instruments within their own equipment. Most often this results in a bespoke design in which various functions are combined into one micro fluidic system. The IQ FLOW concept offers the following functional modules within the 0.75" footprint:

- ◆ Flow meter; typical flow ranges from 20 sccm to 2000 sccm (Full Scale values)
- ◆ Pressure meter; typical pressure ranges of the order of 100 psi
- ◆ Control valve
- ◆ Three-way valve
- ◆ Shut-off valve
- ◆ Filter
- ◆ Mixing chamber



A combination of these modules can be mounted on a compact manifold, in line with a customer's requirement, and following open design discussions. Further possibilities might include either an aluminium or a stainless steel manifold with perhaps female inlet/outlet ports that could be suitable for either gas or liquid. As there are truly an infinite number of possible solutions we highly recommend you to contact Bronkhorst High-Tech to discuss your application.

> High intrinsic quality, featuring...

- ◆ Very stable Zero, due to the thermally balanced chip-sensor
- ◆ Compact assembly ensures space efficiency
- ◆ Economical solution, low cost of ownership
- ◆ Tubeless construction reduces potential leak points
- ◆ Top-mount modules; easily accessible
- ◆ Pre-tested "Plug and Play" units, reducing custom testing requirements
- ◆ Analog and digital (RS232) communication

> Analytical applications

Examples of analytical applications based on the ultra compact modules with a footprint of 0.75" are:

- ◆ Flow - Pressure control at the injector side of a GC
- ◆ Flow control at the detector side of a GC or HPLC
- ◆ Flow control in an FID detector



Bronkhorst[®]
HIGH-TECH

> Technical specifications

Performance specifications

Accuracy flow sensor (based on actual calibration)	: standard $\pm 0.8\%$ Rd + $\pm 0.2\%$ FS, other on request
Accuracy pressure sensor	: < 0.5% FS
Repeatability	: < 0.2% Rd
Settling time (controller)	: < 0.5 second
Temperature sensitivity	: $\pm 0.1\%$ FS/ $^{\circ}$ C
Attitude sensitivity	: negligible

Mechanical specifications

Material (wetted parts)	: stainless steel 316, Si, SiOx, epoxy; option: aluminium body
Process connections	: 10/32 UNF / $\frac{1}{16}$ " or $\frac{1}{8}$ " OD compression type; other on request
Seals	: Viton [®] ; other on request
Weight	: approx. 0,2 kg

Electrical specifications

Readout sample time	: 15 ms
Readout resolution	: 15 bits (0.003% FS)
Power supply	: +15...+24 Vdc, 50 mA for meter; add 50 mA for control valve
Analog output/command	: 0...5 (10) Vdc or 0 (4)...20 mA (sourcing output)
Digital communication	: standard: RS-232; other on request
Electrical connection	: RJ45 modular jack
Ingress protection	: IP40

Operating conditions

Flow capacity (typical) (Intermediate ranges available)	: N2/Air: 0...50 / 0...2000 sccm; H2/He: 0...20 / 0...500 sccm
Turndown	: 1:50 (2...100%)
Pressure ranges (typical)	: 0...5 / 0...15 / 0...30 / 0...100 psig; 0...15 / 0...30 / 0...100 / 0...150 psia
Media	: dry, clean and non-explosive gases
Operating temperature	: 5...50 $^{\circ}$ C
Max. operating pressure	: 10 bara (150 psia)
Pressure drop flow meter	: max. 40 mbar dif. (0.6 psi dif.), based on max. flow of 2 SLM Air
Mounting position	: any position

> Dimensions (mm)

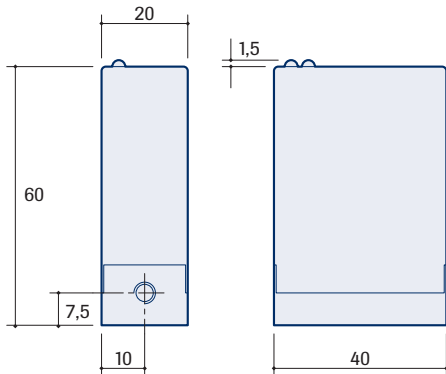

Technical specifications and dimensions
subject to change without notice.

> World's smallest Mass Flow and Pressure Controllers - with MEMS Sensor Technology



IQP-700 Pressure Controller (Picture scale 1 : 1)



IQF-200 Downported Mass Flow Controller (Picture scale 1 : 1)



Example of customised manifold
solution with Flow / Pressure Control

Bronkhorst
HIGH-TECH

Nijverheidsstraat 1a, NL-7261 AK Ruurlo The Netherlands

T +31(0)573 45 88 00 F +31(0)573 45 88 08 I www.bronkhorst.com E info@bronkhorst.com



U.IQF0207A
BHT7014©CAPAY